

# PANEL FANS

*JUST COOL!*



## BUILT FOR THRUST



Looking for a way to keep your cows comfortable and healthy? Our **East Rock Panel fans** are the perfect solution! These fans not only keep your cows cool but also help keep pesky insects away and dry out bedding. Whether you have a tunnel or naturally ventilated barn, these fans are great for recirculating and distributing air, ensuring that your facility stays clean and fresh for your herd and employees.

Our panel fans are designed with you in mind- they are easy to clean and maintain and are built to provide years of trouble-free service. We offer a variety of standard and high-efficiency options to choose from, and a range of sizes, including 36", 50", 55", 72", and 84". These lightweight fans are a smart investment for any barn or facility.



### COVERAGE AREA

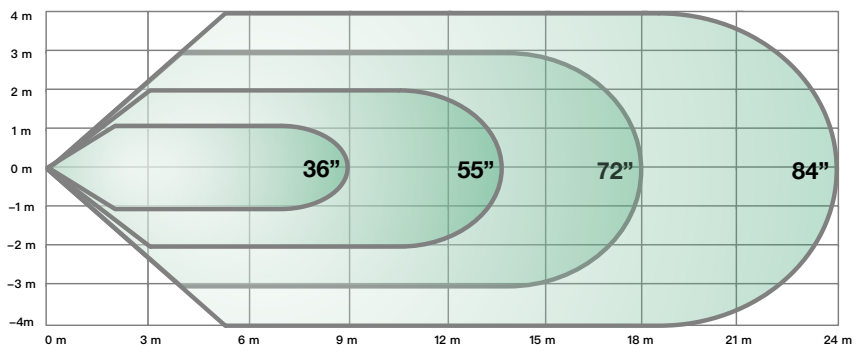

\* Coverage area is based on an average of 2 m/s at cow level (1 meter above ground). Some regions require 3m/s, consult our representative.





## OPTIONS

- Available sizes: 36" (915mm), 55" (1,400mm), 72" (1,830mm) and 84" (2,130)
- Available in Belt Drive and Direct Drive versions
- Save electricity with our Variable speed options
- Multiple shutter options and winter accessories
- High-Pressure Fogging attachments for extra cooling power

## FEATURES AND BENEFITS

- Housing made of Fiberglass composite for a durable, UV-resistant and corrosion-free product
- Round and smooth housing to maximize efficiency and minimize cleaning frequency.
- Formed aluminium blades on Belt Drive and nylon blades on Direct Drive
- Belts can be changed quickly without removing any fan parts
- cULus or CE certified motors
- Stainless Steel #304 Hardware of all fans

## DIMENSIONS(mm)

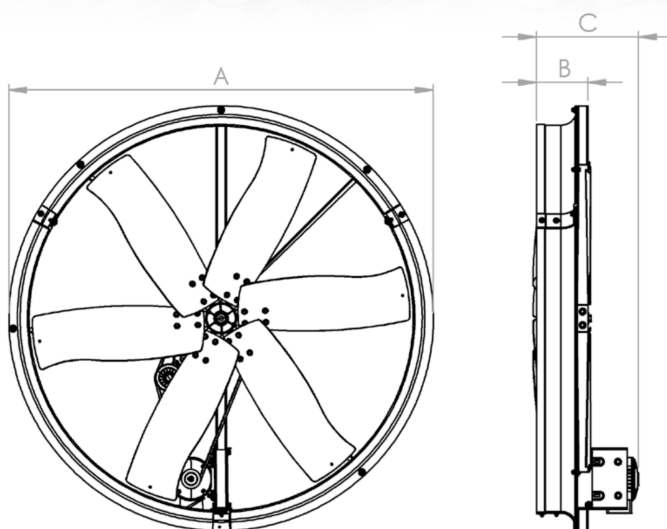

## PEAK PERFORMANCES

Panel fan 36: 18,500 m<sup>3</sup>/h

Panel fan 55: 48,700 m<sup>3</sup>/h

Panel fan 72: 74,800 m<sup>3</sup>/h

Panel fan 84: 108,700 m<sup>3</sup>/h

Model	36"	55"	72"	84"
Fan dia.	915	1,400	1,830	2,130
A	1,090	1,570	2,080	2,360
B	135	190	300	300
C	290	380	457	475

## PERFORMANCE

Model	Drive	Ph	Volt	Hz	kW	Amps	RPM	Speed	Watts	N	N/kW	m <sup>3</sup> /h	WV/1000m <sup>3</sup> /h
36	DD	1	230	50	0.37	2.1	940	100%	537.0	48.40	90.00	18,650	28.80
36	DD	3	400	50	0.37	1.3	940	100%	469.0	47.80	102.00	18,530	25.30
55	BD	3	230/400	50	1.10	4.6/2.7	388	100%	1,158.0	101.00	87.00	40,950	28.30
55	DD *	3	360-460	50/60	1.10	2.1	600	90%	954.0	114.00	120.00	43,740	21.80
72	BD	3	230/400	50	2.20	7.9/4.6	348	100%	2,217.0	180.00	81.00	71,930	30.80
72	DD	3	400	50	3.00	5.2	380	100%	1,863.0	192.00	103.00	74,210	25.10
84	BD	3	400	50	4.00	7.9	349	100%	3,470.0	294.00	84.80	106,400	32.60
84	DD	3	400	50	4.00	6.8	350	100%	2,659.0	272.00	102.00	101,980	26.00

\* EC motor with integrated variable speed control using 0-10VDC and/or Modbus communication. Also available in Single phase version.

1) All fans are tested in accordance with AMCA 230-15 standard.

2) Other motor configuration available

3) Ask your representative about our various Direct Drive models